

Mattole Valley Charter School

INVITATION FOR BIDS

Proposition 39

HVAC Upgrade Project 17-025

DEADLINE FOR SUBMITTING BIDS:

2 p.m., Thursday, October 26, 2017

All bids must be submitted in person or by mail to:

Patricia Terry, Project Manager

Redwood Coast Energy Authority (RCEA)

633 3rd Street

Eureka, CA, 95501

Mandatory Pre-Bid Conference

A mandatory pre-bid conference will be held to acquaint all prospective bidders with the Contract Documents and the Project site. Failure to attend the conference may result in the disqualification of the bid of the non-attending bidder. All questions presented should be submitted in writing.

Date: Thursday, October 12, 2017

Time: 9:00 a.m.

Location: Diamond View Learning Center
505 S Broadway St
Yreka, CA 96097

Contacts: Patricia Terry, Project Manager
pterry@redwoodenergy.org
(707) 269-1700

Shari Lovett, Superintendent
slovett@mattolevalley.org
(707) 445-2660

OVERVIEW

Mattole Valley Charter School is soliciting bids from interested contractors to implement HVAC improvements at their campus. The goal of the project is to reduce energy use at their facilities. The expected work product is to install identified capital improvements that will reduce the overall energy usage and comply with California Energy Commission (CEC) guidelines for the use of Proposition 39 funding.

The District seeks a contractor to complete the following:

- Install (4) ductless mini-split heat pumps.

A proposed schedule indicating the timeline for this solicitation is presented below.

SCHEDULE

The following is a schedule of significant events and deadlines:

Issue Date	Wednesday, October 4, 2017
Mandatory pre-bid conference:	9:00 a.m., Thursday, October 12, 2017
Bids due:	By 2 p.m., Thursday, October 26, 2017
Public bid opening:	After 2 p.m., Thursday, October 26, 2017
Anticipated bid award date:	Friday, November 3, 2017
Installation start date:	November 20, 2017
Installation complete:	no later than December 30, 2017

PROP 39 CONSTRUCTION BID DOCUMENTS
Contract (K-12) (\$15,000 to \$100,000)

TABLE OF CONTENTS

1. Notice Inviting Bids
2. Scope of Work
3. Instructions to Bidders
4. Bid Proposal Form
5. Subcontractor List Form
6. Workers' Compensation Certificate
7. Non-Collusion Affidavit
8. Bid Bond
9. Bidders' Questionnaire
10. Contract
11. General Conditions
12. Appendices
13. Notice of Award
14. Notice to Proceed
15. Performance Bond and Payment Bond Forms
(Bonds are not required for contracts under \$25k)
16. Guarantee

NOTICE INVITING BIDS
Mattole Valley Charter School
Proposition 39 HVAC Upgrade Project

1. Notice is hereby given that the Governing Board of the Mattole Valley Charter School (“District”), County of Humboldt, State of California, will receive sealed bids for the HVAC Upgrade Project (“Project”) up to, but not later than, 2 p.m., on Thursday, October 26, 2017, and will thereafter publicly open and read aloud the bids. **All bids shall be received at the office of Redwood Coast Energy Authority (“RCEA”), 633 Third Street, Eureka, California.**
2. Each bid shall be completed on the Bid Proposal Form included in the Contract Documents, and must conform and be fully responsive to this invitation, the plans, specifications and all other Contract Documents. Copies of the Contract Documents are available for examination at RCEA, 633 3rd Street, Eureka, California, and at the RCEA website <http://redwoodenergy.org/services/bid-opportunities>, and may be obtained by licensed contractors upon request.
3. Each bid shall be accompanied by cash, a cashier's or certified check, or a bidder's bond executed by a surety licensed to do business in the State of California as a surety, made payable to the District, in an amount not less than ten percent (10%) of the maximum amount of the bid. The check or bid bond shall be given as a guarantee that the bidder to whom the contract is awarded will execute the Contract Documents and will provide the required payment and performance bonds and insurance certificates within ten (10) days after the notification of the award of the Contract.
4. The successful bidder shall comply with the provisions of the Labor Code pertaining to payment of the generally prevailing rate of wages and apprenticeships or other training programs. The Department of Industrial Relations has made available the general prevailing rate of per diem wages in the locality in which the work is to be performed for each craft, classification or type of worker needed to execute the Contract, including employer payments for health and welfare, pension, vacation, apprenticeship and similar purposes. Copies of these prevailing rates are available to any interested party upon request and are online at <http://www.dir.ca.gov/DLSR>. The Contractor and all Subcontractors shall pay not less than the specified rates to all workers employed by them in the execution of the Contract. It is the Contractor's responsibility to determine any rate change.
5. The schedule of per diem wages is based upon a working day of eight hours. The rate for holiday and overtime work shall be at least time and one half.
6. The substitution of appropriate securities in lieu of retention amounts from progress payments in accordance with Public Contract Code §22300 is permitted.

7. Pursuant to Public Contract Code §4104, each bid shall include the name and location of the place of business of each subcontractor who shall perform work or service or fabricate or install work for the contractor in excess of one-half of one percent (1/2 of 1%) of the bid price. The bid shall describe the type of the work to be performed by each listed subcontractor.
8. No bid may be withdrawn for a period of sixty (60) days after the date set for the opening for bids except as provided by Public Contract Code §§5100 *et seq.* The District reserves the right to reject any and all bids and to waive any informalities or irregularities in the bidding.
9. Minority, women, and disabled veteran contractors are encouraged to submit bids. This bid is / is not subject to Disabled Veteran Business Enterprise requirements.
10. The project is subject to compliance monitoring and enforcement by the California Department of Industrial Relations. In accordance with Labor Code sections 1725.5 and 1770 *et seq.*, all bidders, contractors and subcontractors working at the site shall be duly registered with the Department of Industrial Relations at time of bid opening and at all relevant times. Proof of registration shall be provided as to all such contractors prior to the commencement of any work.

This project is / is not subject to reporting directly to the California Department of Industrial Relations pursuant to Labor Code sections 1725.5 and 1770 *et seq.* Contractors are still required to maintain certified payroll records on a continuous basis, submit them to the District and provide them to the Labor Commissioner's Office upon request.
11. Each bidder shall possess at the time the bid is awarded the following classification(s) of California State Contractor's license: B- General or C-20 Warm-air Heating, Ventilation and Air-Conditioning.
13. Bidders' Conference. A mandatory bidders' conference will be held at **Diamond View Learning Center on October 12, 2017 at 9:00 a.m.** for the purpose of acquainting all prospective bidders with the Contract Documents and the Project site. Failure to attend the conference may result in the disqualification of the bid of the non-attending bidder.

 No Bidders' Conference.

Mattole Valley Charter School

By: Shari Lovett, Superintendent

DATED: October 4, 2017

Publication Dates: 1) October 4, 2017 2) October 11, 2017

SCOPE OF WORK

Mattole Valley Charter School (“District”) is soliciting bids from licensed and qualified contractors for the following scope of work at the Diamond View Learning Center in Yreka, California.

The selected contractor will:

1. **Base Bid:** Provide and install four (4) single zone mini-split heat pumps, SEER 20.5 and HSPF 10.0, MSZ/MUZ-GL24NA-U1 or equivalent.
 - a. Location
 - i. See Appendix 1 for a Site Map.
 - ii. Locations of outside units will be determined at the site visit.
 - b. Mechanical
 - i. Provide and install four (4) new SEER 20.5, HSPF 10.0 or greater, single-zone mini-split ductless heat pumps.
 - ii. Provide, run, and install necessary refrigerant lines.
 - c. Electrical
 - i. Provide, run, and install necessary electrical upgrade to accommodate units.
 - d. Structural
 - i. Provide and install protective/vandal proof caging around outdoor unit.
 - ii. Provide additional support as needed.
 - e. Permitting and Reporting
 - i. Report costs and other information as needed to meet Prop 39 reporting requirements.
 - f. Temperature Controls
 - i. Provide and install compatible 7-day programmable thermostat.
 - ii. Ensure proper operation of thermostatic zone control.
 - g. Title 24
 - i. System must comply with 2016 Building Energy Efficiency Standards (Title 24, Section 6)
 2. Coordinate with the District and Redwood Coast Energy Authority to ensure adherence to Proposition 39 program guidelines.
 - a. All project services will comply with Proposition 39: California Clean Energy Jobs Act – 2016 Program Implementation Guidelines, which can be found at <http://www.energy.ca.gov/2016publications/CEC-400-2016-005/CEC-400-2016-005-CMF.pdf>.
 - b. To comply with Proposition 39 reporting requirements, Contractor will report post-installation costs by measure.
 3. In addition to completing the scope defined in (1) and (2):
 - a. Verify all heat pumps are operational post installation. If not operational, correct and verify.
 - b. Provide briefing on the installed equipment and proper operation to school facilities manager.
-

INSTRUCTIONS TO BIDDERS

Each bid submitted to the Mattole Valley Charter School (“District”) for the HVAC Upgrade Project (“Project”) shall be in accordance with the following instructions and requirements, which are part of the Contract Documents for this Project.

1. Deadline for Receipt of Bids. Each bid shall be sealed and submitted to the Redwood Coast Energy Authority, 633 3rd Street, Eureka, no later than 2 p.m. on Thursday, October 26, 2017. The District suggests that bids be hand delivered in order to ensure their timely receipt. Any bids received after the time stated, regardless of the reason, shall be returned, unopened, to the bidder.

SUBMITTAL OF RESPONSES

Proposals shall be received at the RCEA office at or before 2 p.m. on Thursday, October 26, 2017

ALL MAILED PROPOSALS SHALL BE ADDRESSED AS FOLLOWS:

BID NO. 17-025
Attn: Patricia Terry, Project Manager
Redwood Coast Energy Authority
633 3rd Street
Eureka, CA 95501

The envelope shall also indicate the name and address of the submitting firm, with “DO NOT OPEN UNTIL BID OPENING” on the front of the envelope.

HAND DELIVERED COURIER OR PACKAGED DELIVERED SERVICE SHALL BE DELIVERED DIRECTLY TO:

Redwood Coast Energy Authority
633 3rd Street
Eureka, CA 95501

2. Mandatory Pre-Bid Conference. A mandatory pre-bid site visit and question forum will be held on Thursday, October 12, 2017 at 9:00 a.m. local time for the purpose of acquainting all prospective bidders with the Contract Documents and the Project site. This will be the bidder’s time to look at the installation site and ask any questions about the project.

The pre-bid site visit will begin at the following location:

Diamond View Learning Center
505 S Broadway St
Yreka, CA 96097

3. Requests for Information. A bidder's failure to request clarification or interpretation of an apparent error, inconsistency or ambiguity in the Contract Documents waives that bidder's right to thereafter claim entitlement to additional compensation based upon an ambiguity, inconsistency, or error, which should have been discovered by a reasonably prudent Contractor, subject to the limitations of Public Contract Code §1104. Any questions relative to the bid shall be in writing and directed to the District Superintendent or designee at the address specified for receipt of bid proposals. These requests shall be submitted to the District at least five working days prior to the date the bid is due.
4. Bid Proposal Forms. All bid proposals shall be made on the form provided by the District. All items on the form shall be filled out in ink. Numbers should be stated in figures, and the signatures of all individuals must be in long hand. The completed form should be without interlineations, alterations, or erasures.
5. Execution of Forms. Each bid shall give the full business address of the bidder and must be signed by the bidder or bidder's authorized representative with his or her usual signature. Bids by partnerships must furnish the full names of all partners and must be signed in the partnership name by a general partner with authority to bind the partnership in such matters. Bids by corporations must be signed with the legal name of the corporation, followed by the signature and designation of the president, secretary, or other person authorized to bind the corporation in this matter. The name of each person signing shall also be typed or printed below the signature. When requested by the District, satisfactory evidence of the authority of the officer signing on behalf of the corporation or partnership shall be furnished. A bidder's failure to properly sign required forms may result in rejection of the bid. All bids must include the bidder's contractor license number(s) and expiration date(s).
6. Bid Security. Bid proposals shall be accompanied by a certified or cashier's check or bid bond for an amount not less than ten percent (10%) of the bid amount, payable to the District. A bid bond shall be secured from an admitted surety company, licensed in the State of California, and satisfactory to the District. The bid security shall be given as a guarantee that the bidder will enter into the Contract if awarded the work, and in the case of refusal or failure to enter into the Contract within ten (10) calendar days after notification of the award of the Contract or failure to provide the payment and performance bonds and proof of insurance as required by the Contract Documents, the District shall have the right to award the Contract to another bidder and declare the bid security forfeited. The District reserves the right to pursue all other remedies in law or equity relating to such a breach including, but not limited to, seeking recovery of damages for breach of contract. Failure to provide bid security, or bid security in the proper amount, shall result in rejection of the bid.
7. Withdrawal of Bid Proposals. Bid proposals may be withdrawn by the bidders prior to the time fixed for the opening of bids, but may not be withdrawn for a period of sixty (60) days after the opening of bids, except as permitted pursuant to Public Contract Code §5103.

8. Addenda or Bulletins. The District reserves the right to issue addenda or bulletins prior to the opening of the bids subject to the limitations of Public Contract Code §4104.5. Any addenda or bulletins issued prior to bid time shall be considered a part of the Contract Documents.
9. Bonds. The successful bidder shall be required to submit payment and performance bonds as specified in and using the bond forms included with the Contract Documents. All required bonds shall be based on the maximum total contract price as awarded, including additive alternates, if applicable.
10. Rejection of Bids and Award of Contract. The District reserves the right to waive any irregularities in the bid and reserves the right to reject any and all bids. The Contract will be awarded, if at all, within sixty (60) calendar days after the opening of bids to the lowest responsible and responsive bidder, subject to Governing Board approval. The time for awarding the Contract may be extended by the District with the consent of the lowest responsible, responsive bidder.
11. Execution of Contract. The successful bidder shall, within ten (10) calendar days of the Notice of Award of the Contract, sign and deliver to the District the executed contract along with the bonds and certificates of insurance required by the Contract Documents. In the event the successful bidder fails or refuses to execute the Contract or fails to provide the bonds and certificates as required, the District may declare the bidder's bid deposit or bond forfeited as liquidated damages, and may award the work to the next lowest responsible, responsive bidder, or may reject all bids and, in its sole discretion, call for new bids. In all cases, the District reserves the right, without any liability, to cancel the award of Contract at any time prior to the full execution of the Contract.
12. Drawings and Specifications. All drawings, specifications and other documents used or prepared during the project shall be the exclusive property of the District.
13. Evidence of Responsibility. Upon the request of the District, a bidder shall submit promptly to the District satisfactory evidence showing the bidder's financial resources, the bidder's experience in the type of work being required by the District, the bidder's availability to perform the Contract and any other required evidence of the bidder's qualifications and responsibility to perform the Contract. The District may consider such evidence before making its decision to award the Contract. Failure to submit requested evidence may result in rejection of the bid.
14. Taxes. Applicable taxes shall be included in the bid prices.
15. Bid Exceptions. Bid exceptions are not allowed. If the Bidder has a comment regarding the bid documents or the scope of work, the Bidder shall submit those comments to the District for evaluation at least five working days prior to the opening of the bids. No oral or telephonic modification of any bid submitted will be considered and a sealed written modification may be considered only if received prior to the opening of bids. E-mailed or faxed bids or modifications will not be accepted.

16. Discounts. Any discounts which the bidder desires to provide the District must be stated clearly on the bid form itself so that the District can calculate the net cost of the bid proposal. Offers of discounts or additional services not delineated on the bid form will not be considered by the District in the determination of the lowest responsible responsive bidder.
17. Quantities. The quantities shown on the plans and specifications are approximate. The District reserves the right to increase or decrease quantities as desired.
18. Prices. Bidders must quote prices F.O.B. unless otherwise noted. Prices should be stated in the units specified and bidders should quote each item separately.
19. Samples. On request, samples of the products being bid shall be furnished to the District.
20. Special Brand Names/Substitutions. In describing any item, the use of a manufacturer or special brand does not restrict bidding to that manufacturer or special brand, but is intended only to indicate quality and type of item desired, except as provided in §3400 of the Public Contract Code. Substitute products will be considered either prior to or after the award of the Contract in accordance with §3400 and as set forth in the General Conditions, Supplemental Conditions or the Specifications. All data substantiating the proposed substitute as an "equal" item shall be submitted with the written request for substitution. The District reserves the right to make all final decisions on product and vendor selection.
21. Container Costs and Delivery. All costs for containers shall be borne by the bidder. All products shall conform to the provisions set forth in the federal, county, state and city laws for their production, handling, processing and labeling. Packages shall be so constructed to ensure safe transportation to the point of delivery.
22. Bid Negotiations. A bid response to any specific item of the bid using terms such as "negotiable," "will negotiate," or similar phrases, will be considered non-responsive.
23. Prevailing Law. In the event of any conflict or ambiguity between these instructions and state or federal law or regulations, the latter shall prevail. All equipment to be supplied or services to be performed under the bid proposal shall conform to all applicable requirements of local, state and federal law, including, but not limited to, Labor Code §§1771, 1778 and 1779.
24. Allowances. An "allowance" means an amount included in the bid proposal for work that may or may not be included in the Project, depending on conditions that will become known only after the Project is underway.
25. Subcontractors. Pursuant to the Subletting and Subcontracting Fair Practices Act, Public Contract Code §§4100-4114, every bidder shall, on the enclosed Subcontractor List Form, set forth:

- a. The name and location of the place of business of each Subcontractor who will perform work or labor or render service to the bidder in or about the work or fabricate and install work in an amount in excess of one-half (1/2) of the one percent (1%) of the bidder's total bid.
 - b. If the bidder fails to specify a Subcontractor for any portion of the work to be performed under the Contract in excess of one-half (1/2) of one percent (1%) of the bidder's total bid, bidder agrees that bidder is fully qualified to and shall perform that portion of the work. The successful bidder shall not, without the written consent of the District or compliance with Public Contract Code §§4100 - 4114, either:
 - 1) Substitute any person as Subcontractor in place of the Subcontractor designated in the original bid;
 - 2) Permit any subcontract to be voluntarily assigned or transferred or allow the work to be performed by anyone other than the original Subcontractor listed in the bid; or
 - 3) Sublet or subcontract any portion of the work in excess of one-half (1/2) of one percent (1%) of the total bid as to which the bidder's original bid did not designate a Subcontractor.
26. Examination of Contract Documents and Work Site. Before submitting a bid proposal, all bidders shall carefully examine the Contract Documents, including the plans and specifications, shall visit the site of the proposed work, and shall fully inform themselves of all conditions in and about the work site, as well as applicable federal, state and local laws and regulations that may affect the work. No bidder shall visit the site without prior authorization of the District. Bidders shall contact the District Superintendent or designee for coordination of site visits.
27. Form and Approval of Contract. The Contract Documents must be approved by the Governing Board of the District and its legal counsel. The bidder selected by the District shall execute the contract provided by the District.
28. Licenses and Permits. Each bidder, and its Subcontractors, if any, shall at all times possess all appropriate and required licenses or other permits to perform the work as identified in the Contract Documents. Upon request, each bidder shall furnish the District with evidence demonstrating possession of the required licenses or permits.
29. Denial of Right to Bid. Contractors or Subcontractors who have violated state law governing public works shall be denied the right to bid on this public works contract pursuant to Labor Code §1777.7.
30. Bidders Interested in More Than One Bid. No person, firm, or corporation shall make, or file, or be interested in more than one bid. However, a person, firm, or corporation that has submitted a sub-proposal to a bidder, or that has quoted prices of materials to a bidder, is not

thereby disqualified from submitting a sub-proposal or quoting prices to other bidders or from submitting a prime proposal.

31. Contractor's State License Board. Contractors and Subcontractors are required by law to be licensed and regulated by the California Contractors' License Board.
32. Fingerprinting. By law it is the District's responsibility to determine whether a contractor must provide fingerprint certification. Pursuant to Education Code §45125.2, the District considers the totality of the circumstances in order to determine if fingerprinting of employees of a contractor working on a school site is required. Factors to be considered include the length of time the contractor's employees are on school grounds, whether students are in proximity to the location where the contractor's employees are working, and whether the contractor's employees are working alone or with others.
33. Disabled Veterans Participation Goals. This Contract is / is not subject to Education Code §17076.11, Pursuant to that section, this District has established a participation goal for disabled veteran business enterprises ("DVBE") of at least 3 percent per year of the overall dollar amount of funds allocated to the District by the State Allocation Board pursuant to the Leroy F. Greene School Facilities Act of 1998 for construction or modernization and expended each year by the District. Prior to, and as a condition precedent for final payment under the Contract for the project, the Contractor shall provide appropriate documentation to the District identifying the amount paid to DBVE in conjunction with the contract, so that the District can assess its success at meeting this goal. The Office of Small Business and DVBE Certification (OSDC), (916) 375-4940, www.pd.dgs.ca.gov/smbus/default.htm, is an information resource to assist bidders in locating Disabled Veteran Business Enterprises. (Please note: while the OSDC may be used as a resource, the DVBE Program administered by OSDC applies to state contracts, not local agency (school district) contracts.)
34. Labor Compliance. This project is / is not subject to compliance monitoring and enforcement by the California Department of Industrial Relations pursuant to Labor Code sections 1725.5 and 1770 *et seq.* In accordance with Labor Code sections 1725.5 and 1770 *et seq.*, all bidders, contractors and subcontractors working at the site shall be duly registered with the Department of Industrial Relations at time of bid opening and at all relevant times. Proof of registration shall be provided as to all such contractors prior to the commencement of any work. If this project is under \$25,000.00, in accordance with SB 96 Labor Code 1771.1, the bidder awarded this project will not be required to upload their certified payrolls to the DIR. They will be required to maintain records and release them to the District and Project Manager for the project record.
36. Additive and Deductive Items: Method of Determining Lowest Bid. Pursuant to Public Contract Code §20103.8, if the bid solicitation includes additive and/or deductive items, the checked [X] method shall be used to determine the lowest bid: *[check one]*

(a) The lowest bid shall be the lowest bid price on the base contract without

consideration of the prices on the additive or deductive items.

(b) The lowest bid shall be the lowest total of the bid prices on the base contract and those additive or deductive items that were specifically identified in the bid solicitation or Bid Proposal Form as being used for the purpose of determining the lowest bid price.

(c) The lowest bid shall be the lowest total of the bid prices on the base contract and those additive or deductive items taken in order from a specifically identified list of those items that, when in the solicitation, and added to, or subtracted from, the base contract, are less than, or equal to, a funding amount publicly disclosed by the District before the first bid is opened.

(d) The lowest bid shall be determined in a manner that prevents any information that would identify any of the bidders or the proposed Subcontractors or suppliers from being revealed to the public entity before the ranking of all bidders from lowest to highest has been determined.

If no method is checked, sub-paragraph (a) shall be used to determine the lowest bid.

Notwithstanding the method used by the District to determine the lowest responsible bidder, the District retains the right to add to or deduct from the Contract any of the items included in the bid solicitation.

37. Bid Protest. Any bid protest must be in writing and received by the District Office before 5:00 p.m. no later than three (3) working days following bid opening and shall comply with the following requirements:

- a. The bid protest must contain a complete statement of the basis for the protest and all supporting documentation.
- b. The party filing the protest must have actually submitted a bid for the Project. A Subcontractor of a bidder submitting a bid for the Project may not submit a bid protest. A bidder may not rely on the bid protest submitted by another bidder, but must timely pursue its own protest.
- c. The protest must refer to the specific portion or portions of the Contract Documents upon which the protest is based.
- d. The protest must include the name, address and telephone number of the person representing the protesting bidder.
- e. The bidder filing the protest must concurrently transmit a copy of the bid protest and all supporting documentation to all other bidders with a direct financial interest which may be affected by the outcome of the protest, including all other bidders who appear to have a reasonable prospect of receiving an award depending upon the outcome of the protest.

- f. The bidder whose bid has been protested may submit a written response to the bid protest. Such response shall be submitted to the District before 5 p.m. no later than two (2) working days after the deadline for submission of the bid protest or receipt of the bid protest, whichever is sooner, and shall include all supporting documentation. Such response shall also be transmitted concurrently to the protesting bidder and to all other bidders who appear to have a reasonable prospect of receiving an award depending upon the outcome of the protest.
- g. The procedure and time limits set forth in this section are mandatory and are the bidder's sole and exclusive remedy in the event of bid protest. The bidder's failure to comply with these procedures shall constitute a waiver of any right to further pursue the bid protest, including filing a Government Code claim or legal proceedings.
- h. If the District determines that a protest is frivolous, the protesting bidder may be determined to be non-responsible and that bidder may be determined to be ineligible for future contract awards by the District.
- i. A "working day" for purposes of this section means a weekday during which the District's office is open and conducting business, regardless of whether or not school is in session.

-- END --

BID PROPOSAL FORM

Governing Board
Mattole Valley Charter School

Dear Members of the Governing Board:

The undersigned, doing business under the name of <Contractor Name>, having carefully examined the location of the proposed work, the local conditions of the place where the work is to be done, the Notice Inviting Bids, the General Conditions, the Instructions to Bidders, the Plans and Specifications, and all other Contract Documents for the proposed Proposition 39 HVAC Upgrade Project ("Project"), and having accurately completed the Bidder's Questionnaire, proposes to perform all work and activities in accordance with the Contract Documents, including all of its component parts, and to furnish all required labor, materials, equipment, transportation and services required for the construction of the Project in strict conformity with the Contract Documents, including the Plans and Specifications, as follows:

BASE BID:

For the sum of

_____ Dollars (\$ _____).

ADDITIVE/DEDUCTIVE ALTERNATE *[if applicable]*:

Additive/Deductive Alternate #1 _____
Add/Subtract _____ Dollars (\$ _____)

Additive/Deductive Alternate #2 _____
Add/Subtract _____ Dollars (\$ _____)

Additive/Deductive Alternate #3 _____
Add/Subtract _____ Dollars (\$ _____)

The undersigned has checked carefully all the above figures and understands that the District is not responsible for any errors or omissions on the part of the undersigned in making this bid.

Enclosed find certified or cashier's check no. _____ of the _____ Bank for _____ Dollars (\$ _____) or Bidder's Bond of the _____ surety company in an amount of not less than ten percent (10%) of the entire bid. The undersigned further agrees, on the acceptance of this proposal, to execute the Contract and provide the required bonds and insurance and that in case of default in executing these documents within the time fixed by the

Contract Documents, the proceeds of the check or bond accompanying this bid shall be forfeited and shall become the property of the District.

Contractor agrees to commence the work within the time specified in the Notice to Proceed. It is understood that this bid is based upon completing the work within the number of calendar days specified in the Contract Documents.

ADDENDA:

Receipt of the following addenda is hereby acknowledged:

Addendum # _____	Dated: _____	Addendum # _____	Dated: _____
Addendum # _____	Dated: _____	Addendum # _____	Dated: _____
Addendum # _____	Dated: _____	Addendum # _____	Dated: _____

Respectfully submitted,

Company: _____

Address: _____

By: _____

(Please Print Or Type)

Signature: _____

Title: _____

Date: _____

Telephone: _____

Contractor's License No: _____ Expiration Date _____

DIR Registration No. (if applicable) _____

Required Attachments: Subcontractor List Form

Workers' Compensation Certificate

Non-Collusion Affidavit

Bid Bond (or Cashier's or Certified Check)

Bidders' Questionnaire

SUBCONTRACTOR LIST FORM

Each bidder shall list below the name and location of place of business for each Subcontractor who will perform a portion of the Contract work in an amount in excess of 1/2 of 1 percent of the total contract price. The nature of the work to be subcontracted shall also be described. Per SB96 Public Contract Code 4104, please list the DIR registration number for each Subcontractor.

DESCRIPTION OF WORK	NAME	LOCATION	LICENSE # & DIR #

WORKERS' COMPENSATION CERTIFICATE

Labor Code §3700 in relevant part provides:

"Every employer except the State shall secure the payment of compensation in one or more of the following ways:

- (a) By being insured against liability to pay compensation in one or more insurers duly authorized to write compensation insurance in this State.
- (b) By securing from the Director of Industrial Relations a certificate of consent to self-insure, which may be given upon furnishing proof satisfactory to the Director of Industrial Relations of ability to self-insure and to pay any compensation that may become due to his employees."

I am aware of the provisions of §3700 of the Labor Code which require every employer to be insured against liability for workers' compensation or to undertake self-insurance in accordance with the provisions of that Code, and I will comply with such provisions before commencing the performance of the work of this Contract and will require all Subcontractors to do the same.

Contractor

By: _____

In accordance with Article 5 (commencing at §1860), Chapter 1, Part 7, Division 2 of the Labor Code, the above certificate must be signed and filed with the awarding body prior to performing any work under this Contract.

NONCOLLUSION AFFIDAVIT

To be executed by the bidder, notarized and submitted with the bid.

STATE OF CALIFORNIA)
) SS
COUNTY OF _____)

_____, declares and says that he or she is _____ of _____, the party making the foregoing bid, and affirms that the bid is not made in the interest of, or on behalf of, any undisclosed person, partnership, company, association, organization, or corporation; that the bid is genuine and not collusive or sham; that the bidder has not directly or indirectly induced or solicited any other bidder to put in a false or sham bid, and has not directly or indirectly colluded, conspired, connived, or agreed with any bidder or anyone else to put in a sham bid, or that anyone shall refrain from bidding; that the bidder has not in any manner, directly or indirectly, sought by agreement, communication, or conference with anyone to fix the bid price of the bidder or any other bidder, or to fix any overhead, profit, or cost element of the bid price, or of that of any other bidder, or to secure any advantage against the public body awarding the contract of anyone interested in the proposed contract; that all statements contained in the bid are true and correct; and, further, that the bidder has not, directly or indirectly, submitted his or her bid price or any breakdown thereof, or the contents thereof, or divulged information or data relative thereto, or paid, and will not pay, any fee to any corporation, partnership, company association, organization, bid depository, or to any member or agent thereof to effectuate a collusive or sham bid.

I declare under penalty of perjury under the laws of the State of California that the foregoing is true and correct.

Date: _____
Signature

BID BOND

We, the Contractor, _____ as principal (“Principal”), and _____, as surety (“Surety”), are firmly bound unto the Mattole Valley Charter School (“District”) in the penal sum of ten percent (10%) of the total amount of the bid of the Principal submitted to the District for the work described below for the payment of which sum in lawful money of the United States, we bind ourselves, our heirs, executors, administrators, successors and assigns, jointly and severally, firmly by this agreement.

Whereas, the Principal has submitted the accompanying bid (“Bid”) dated _____, for the following project (“Project”):

HVAC Upgrade Project.

Now, therefore, if the Principal does not withdraw its Bid within the period specified, and if the Principal is awarded the Contract and within the period specified fails to enter into a written contract with District, in accordance with the Bid as accepted, or fails to provide the proof of required insurance, the performance bond and/or the payment bond by an admitted surety within the time required, or in the event of unauthorized withdrawal of the Bid, if the Principal pays the District the difference between the amount specified in the Bid and the amount for which District may otherwise procure the required work and/or supplies, if the latter amount is in excess of the former, together with all related costs incurred by District, then the above obligation shall be void and of no effect. Otherwise, the Principal and Surety shall pay to the District the penal sum described above as liquidated damages.

Surety, for value received, hereby agrees that no change, extension of time, alteration or addition to the term of the Contract or the call for bids, or to the work to be performed thereunder, or the Specifications accompanying the same, shall in any way affect its obligation under this bond, and it does hereby waive notice of any such change, extension of time, alteration or addition.

In witness whereof the above-bound parties have executed this instrument under their several seals this _____ day of _____, 20__, the name and corporate seal of each corporate Party being hereunder affixed and these presents duly signed by its undersigned representative, pursuant to the authority of its governing body.

(Corporate Seal)

Principal/Contractor

By _____

Title: _____

(Corporate Seal)

Surety

Attach Attorney-In-Fact Certificate

By _____

Title

To be signed by Principal and Surety and Acknowledgment and Notary Seal to be attached.

BIDDER'S QUESTIONNAIRE

for

HVAC Upgrade Project

TO THE BIDDER:

In making its award, the Governing Board will take into consideration the Bidder's experience, financial responsibility and capability. The following questionnaire is a part of the bid. Any bid received without this completed questionnaire may be rejected as nonresponsive. The Board will use, but will not be limited to, the information provided herein for evaluating the qualifications and responsibility of the bidder and the bidder's organization to carry out satisfactorily the terms of the Contract Document. The questionnaire must be filled out accurately and completely and submitted with the bid. Any errors, omissions or misrepresentation of information may be considered as a basis for the rejection of the bid and may be grounds for the termination of any contract executed as a result of the bid.

A. Description of Bidder's Organization

1. Firm Name _____

2. Address _____

3. Telephone Number _____

4. Type of Organization

a. Corporation? Yes ____ No ____

If yes, list the officers and positions, and the State in which incorporated.

If the Bidder corporation is a subsidiary, give name and address of parent corporation.

b. Partnership? Yes ____ No ____

If yes, list partner names and addresses

General Partners:

Limited Partners:

c. Individual Proprietorship? Yes ____ No ____

If yes, list name and address of proprietor:

B. Nature of Operations

1. How long have you been engaged in the contracting business under your present business name? _____
2. How many years of experience does your business have in construction work similar to that called for under this bid? _____
3. Have you now contracts, or have you ever contracted, to provide construction for any school district, community college district or county office of education in the State of California? Yes ____ No ____

a. If "yes," on a separate attached sheet, provide the following information for all construction projects you have had with school districts, community college districts and county offices of education during the last four (4) years:

1. Year contract awarded
2. Type of work
3. Contract completion time called for/actual completion time
4. Contract price
5. For whom performed, including person to call for a reference and telephone number

6. Location of work
7. Number of stop notices filed
8. For each contract, list any lawsuits filed relating to that contract in which you were a defendant or plaintiff
9. Amount of liquidated damages assessed.

b. On a separate attached sheet, provide the following information for all construction contracts of a similar nature as called for in this bid that you have had with entities other than school districts, community college districts and county offices of education during the last four (4) years:

1. Year contract awarded
2. Type of work
3. Contract completion time called for/actual completion time
4. Contract price
5. For whom performed, including person to call for reference and phone number
6. Location of work
7. Number of stop notices filed
8. For each contract list any lawsuits filed relating to that contract in which you were a defendant or plaintiff
9. Amount of liquidated damages assessed.

c. For each construction contract that you have failed to complete within the contract time in the last four years please state the reasons for the untimely performance.

C. Financial and Credit Data

1. If your bid is considered for award, and if requested by the District, will you supply the following data? Yes ____ No ____
 - a. Names and addresses of any banks where you regularly do business.
 - b. The names and addresses of any banks, finance companies, dealers, suppliers, or others where you have notes or loans.
 - c. Give credit references, including at least three trade or industry suppliers with whom you regularly deal.
2. Will you submit on request a balance sheet for the past three (3) years? Yes ____ No ____

3. Where have you engaged in the construction business, or any other type of business, in the last five years?

<u>Name of Business</u>	<u>Location</u>	<u>Type of Business</u>	<u>Years in Business</u>
-------------------------	-----------------	-------------------------	--------------------------

_____	_____	_____	_____
_____	_____	_____	_____
_____	_____	_____	_____

If any of the business endeavors referred to above are no longer operating, or you are no longer associated with them, please give brief details:

4. The following surety companies may be contacted as references as to the financial responsibility and general reliability of the bidder:

<u>Surety Name</u>	<u>Contact Person</u>	<u>Phone Number</u>
--------------------	-----------------------	---------------------

_____	_____	_____
_____	_____	_____
_____	_____	_____

I certify under penalty of perjury that the foregoing is true and correct. Executed at _____, California, on _____, 20__.

Signature of Bidder _____

Name (*print*) _____

Company _____

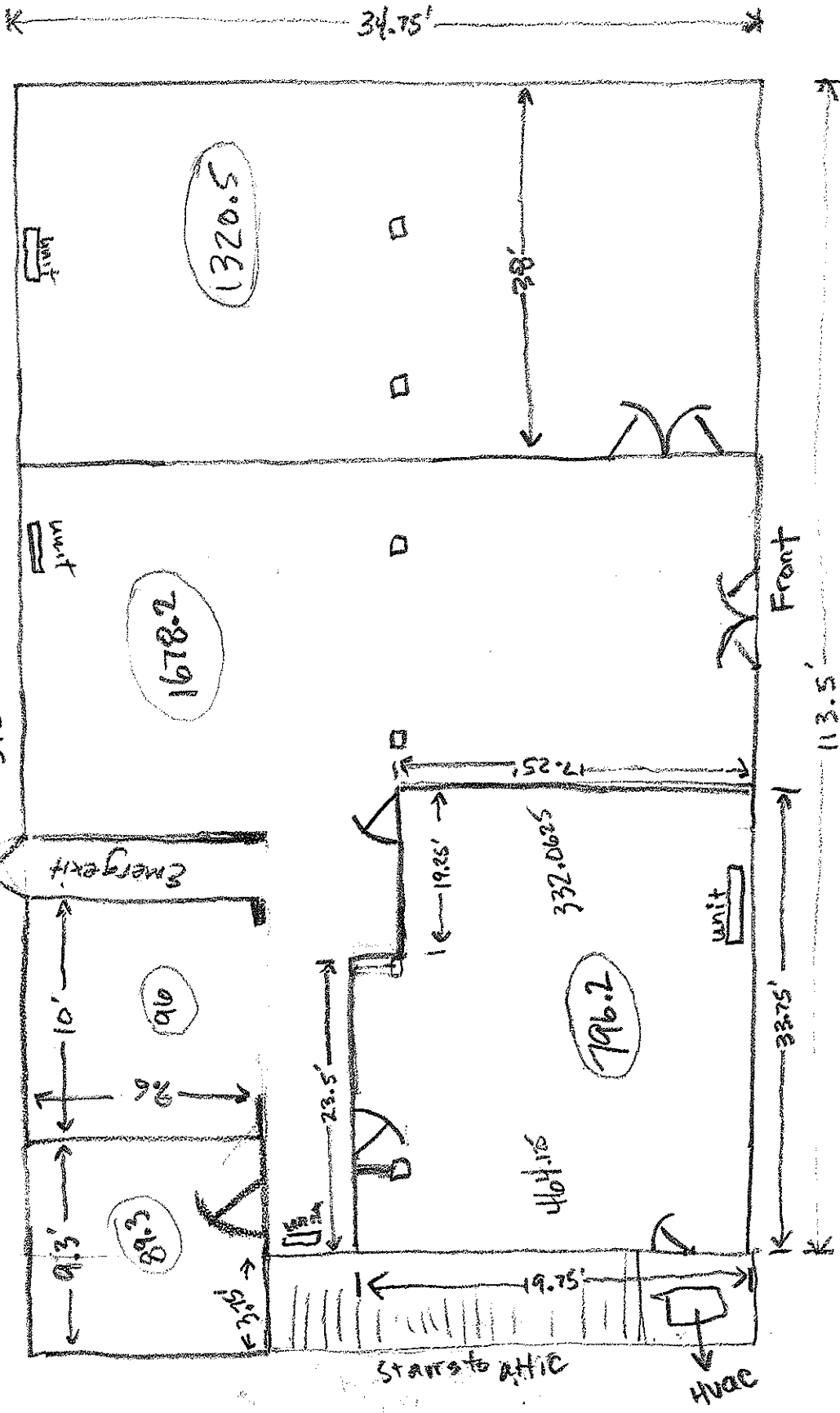

Net drawn to scale!
(obviously)

4074.5
- 94.3

3980.2

1678.2
89.3
96

1863.5

3980.2
< 1320.5 >
< 796.2 >
< 89.3 >
< 96 >

1678.2

MFG NEPD60J22A1
Serial L973 92608
Installed restrictor 089
Design pressure 300 PSIG
Refrigerant 22
Listed 664X

36

94.3

M-SERIES

SUBMITTAL DATA: MSZ-GL24NA-U1 & MUZ-GL24NA-U1

24,000 BTU/H WALL-MOUNTED HEAT PUMP SYSTEM



Job Name: _____
 System Reference: _____ Date: _____

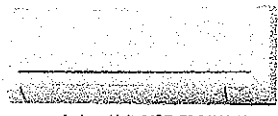

Indoor Unit: MSZ-GL24NA-U1



Wireless Remote Controller

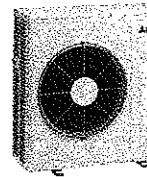

Outdoor Unit: MUZ-GL24NA-U1

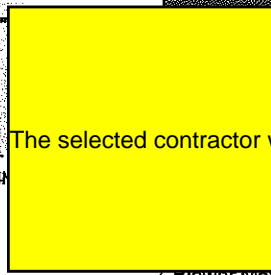

Power	208 / 230V, 1-Phase, 60 Hz
-------	----------------------------

Circuit Ampacity (MCA)	Indoor	A	1 / 17.1
------------------------	--------	---	----------

ACCESSORIES:

Indoor Unit

- Condensate Pump (BlueDiamond X87-711/721; 115/230V)
- Condensate Pump (Sauermann SI30-115/230; 115/230V)
- Anti-Allergy Enzyme Filter (MAC-408FT-E)
- Drain Pan Level Sensor (DPLS2)

Outdoor Unit

- Outdoor Mounting Pad (ULTRILITE1)
- Drain Pan Heater (MAC-642BH-U)
- 3-1/4" Mounting Base [Pair] (DSD-400P)
- Drain Pan Socket (MAC-851DS)
- Air Outlet Guide (MAC-886SG-E)
- Wall Mounting Bracket (QSWB2000M-1)

Controls

- Wireless Controller (MHK1)
- Wired Remote Controller PAR-32MAA (Requires MAC-333IF-E)
- Wireless Interface for kumo cloud™ (PAC-USWHS002-WF-1)
- Thermostat Interface (PAC-US444CN-1)

SPECIFICATIONS:

Rated Conditions (Capacity / Input)		
Cooling ¹	Btu/h / W	22,400 / 1,800
Heating at 47° F ²	Btu/h / W	27,600 / 2,340

Capacity Range		Minimum	Maximum
Cooling ¹	Btu/h	8,200	31,400
Heating at 47° F ²	Btu/h	7,500	36,900
Heating at 17° F ³	Btu/h	-	24,600
Heating at 5° F ⁴	Btu/h	-	21,160

¹ Cooling | Indoor: 80° F (27° C) DB / 67° F (19° C) WB; Outdoor: 95° F (35° C) DB / 75° F (24° C) WB
² Heating at 47° F | Indoor: 70° F (21° C) DB / 60° F (16° C) WB; Outdoor: 47° F (8° C) DB / 43° F (6° C) WB
³ Heating at 17° F | Indoor: 70° F (21° C) DB / 60° F (16° C) WB; Outdoor: 17° F (-8° C) DB / 15° F (-9° C) WB
⁴ Heating at 5° F | Indoor: 70° F (21° C) DB / 60° F (16° C) WB; Outdoor: 5° F (-15° C) DB / 5° F (-15° C) WB
 * Rating Conditions per AHRI Standard:

Operating Conditions (Indoor Intake Air Temp.) (Max. / Min.)	
Cooling ²	90° F (32° C) DB / 67° F (19° C) DB
Heating	80° F (27° C) DB / 70° F (21° C) DB

Operating Conditions (Outdoor Intake Air Temp.) (Max. / Min.)	
Cooling ⁵	115 F (46° C) DB / 14° F (-10° C) DB
Heating	75° F (24° C) DB / -4° F (-20° C) DB**

⁵ Applications should be restricted to comfort cooling only; equipment cooling applications are not recommended for low ambient temperature conditions.
 ** System cuts out at -9° F (-27° C) to avoid thermistor error and automatically restarts at -4° F (-20° C).

AHRI Efficiency Ratings	
SEER / HSPF	20.5 / 10.0
COP at 47° F / 17° F	3.46 / 2.65

Energy Star	Yes
-------------	-----

ENERGY STAR products are third-party certified by an EPA-recognized Certification Body.
 Specifications are subject to change without notice.

Blower Motor Output	W	55
SHF / Moisture Removal	0.75 / 5.1 pt./h	
Field Drainpipe Size O.D.	In.(mm)	5/8 (15)

Outdoor Unit		
Compressor	DC INVERTER-driven Twin Rotary	
Fan Motor (ECM)	FLA	0.93

Airflow Rate (Quiet - Lo - Med - Hi - Super Hi)			
Indoor (Cooling)	DRY	CFM	388-469-544-628-738
	WET		347-420-487-562-661
Indoor (Heating)	DRY		388-469-544-628-738
			1769 / 1701

Sound Pressure Level (Quiet - Lo - Med - Hi - Super Hi)			
Indoor	Cooling	dB(A)	34-41-45-49-53
	Heating		32-41-45-49-52
Outdoor	Cooling		55
	Heating		55

External Dimensions		
Indoor (H x W x D)	In.(mm)	12-13/16 x 43-5/16 x 9-3/8 (325 x 1,100 x 238)
Outdoor (H x W x D)		34-5/8 x 33-1/16 x 13 (880 x 840 x 330)

Net Weight	
Indoor	Lbs.(kg) 37 (17)
Outdoor	119 (54)

External Finish	
Indoor	Munsell 1.0Y 9.2 / 0.2
Outdoor	Munsell No. 3Y 7.8 / 1.1

Refrigerant	R410A; 4 lb. 3 oz.
-------------	--------------------

Refrigerant Piping (Flared)		
Liquid (High Pressure)	In.(mm)	3/8 (9.52)
Gas (Low Pressure)		5/8 (15.88)
Max. Total Refrigerant Pipe Length (Height Diff.)	Ft. (m)	50 (15)
Max. Total Refrigerant Pipe Length (Length.)		100 (30)

DIMENSIONS MSZ-GL24NA-U1 & MUZ-GL24NA-U1

MSZ-GL24NA-U1

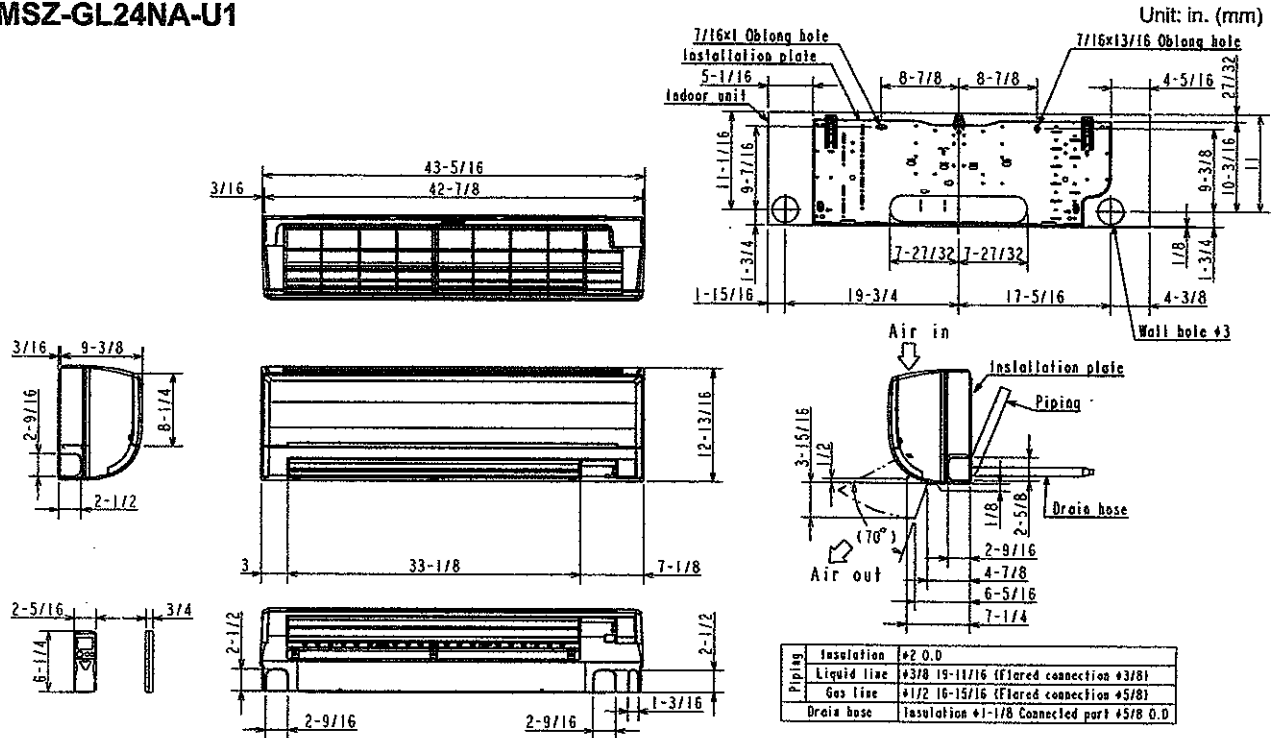

MUZ-GL24NA-U1

REQUIRED SPACE

Unit: in. (mm)

*1 20 in. (500 mm) or more when front and sides of the unit are clear

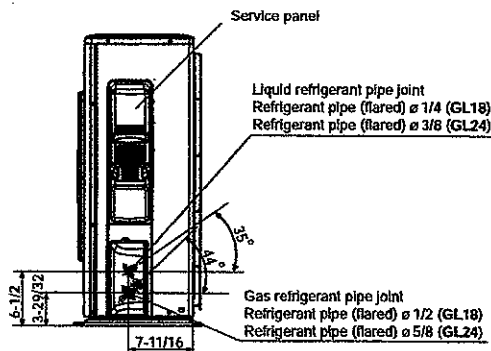
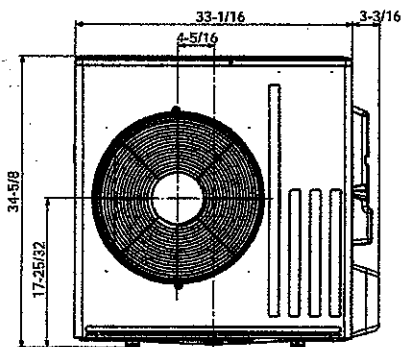
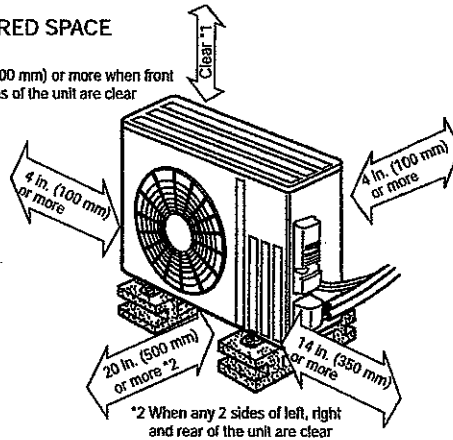
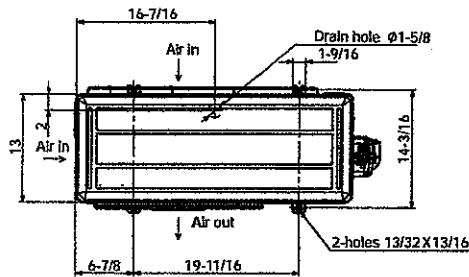

1340 Satellite Boulevard, Suwanee, GA 30024
Toll Free: 800-433-4822 www.mehvac.com

